



6" UTILITY BACKWATER VALVE Installation Instructions

UBWV6-3-1221

Features



Spears® Utility Backwater Valves feature an easily serviceable and replaceable Flapper Assembly with extendable access using standard piping components. Spears® Backwater Valves are designed for direct solvent cement weld connection to ASTM D 2665 PVC DWV or other IPS size pipe. Spears® IPS x Sewer Adapters are available for connection to ASTM 3034 sewer pipe. Backwater Valves conform to requirements of ASME/ANSI A112.14.1.

Utility Back Water Valve includes replaceable Flapper Assembly and requires use of an Extension Kit pressure rated to either 50 psi or 100 psi. Extension Kit includes 8" DWV Cleanout Adapter and a Threaded plug for use with user supplied 8" Schedule 40 or Class 125 Riser Extension Pipe cut to desired length. User supplied 1" or 1-1/4" coupling with 1-1/4" is used for the Internal Extension Pipe.

NOTE: 50 psi rated kits use a DWV cleanout Plug, 100 psi rate kits use a Schedule 40 threaded plug. User supplied equivalent components can also be used.

Valve

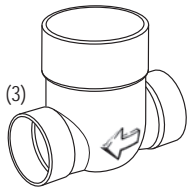

Extension Kit

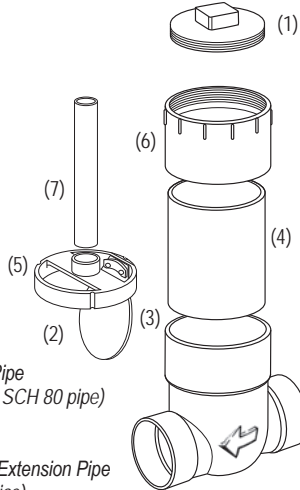

- (1) Access Plug
- (2) Flapper
- (3) Valve Body
- (4) User Supplied 8" Riser Extension Pipe (SCH 40 or Class 125 – do not use SCH 80 pipe)
- (5) Collar
- (6) DWV Cleanout Adapter
- (7) User Supplied 1" or 1-1/4" Internal Extension Pipe (for lifting Flapper Assembly to service)

Read all applicable instructions and procedures thoroughly before starting. Suitability of the intended service application must be determined prior to installation. Plastic piping systems must be engineered, installed, operated and maintained in accordance with accepted standards and procedures for plastic piping systems. It is absolutely necessary that all design, installation, operation and maintenance personnel be trained in proper handling, installation requirements and precautions for installation and use of plastic piping systems.

Backwater Valves are designed to prevent back-flow in numerous applications where easy service access for maintenance and cleaning is needed.

Typical Applications

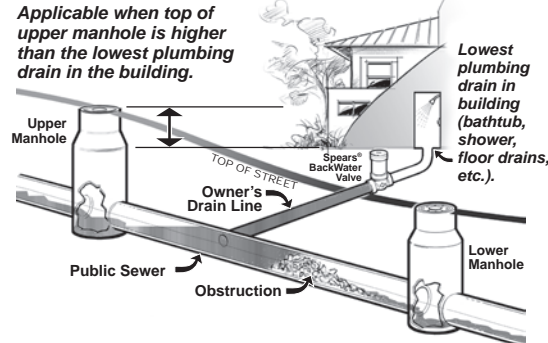

Spears® Backwater Valve is additionally rated to 100 psi for use in balancing multi-level systems such as tank storage and ponds.

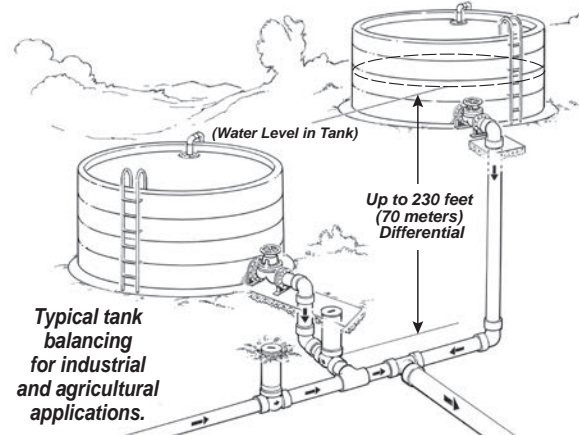
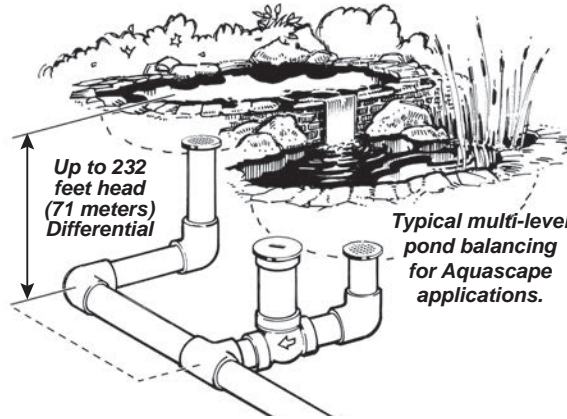

Backwater Valve Pre-Installation Guidelines

Drainage & Slope - The minimum downstream slope is 1/4" per foot or 2%. DO NOT install vertically. Valve body must be installed lower than the flood rim of lowest fixture.

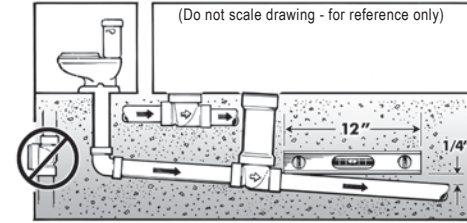

Valve Location & Access Whenever possible, locate valve body/access plug in an exposed, open area to facilitate servicing.

Valve Orientation -

Spears® Backwater Valves must be installed horizontally, with access plug UP and arrow (←) on valve side pointing in the desired flow direction.

Periodic inspection is recommended to ensure that no effluent or debris has obstructed flap movement and proper operation. Worn or damaged Flap Assembly can be easily replaced using snap-in replacement unit.

Precautions for All Valve Installations

- Inspect all parts for damage before proceeding.
- Clean and dry ALL joining components.
- Remove ALL system components from their packaging and expose to the environment for at least one hour.
- Do NOT install if temperature is above 110° F (43° C) or below 40° F (5° C).
- When installed, Valve must be well supported and relieved of ALL mechanical stress loads.
- BEFORE Valve is cycled, all foreign material must be flushed from the system to prevent damage.

Pre-Installation

Slide collar through 8" riser pipe. If collar does not slide freely through pipe, check to see if pipe is "out-of-round". If so, replace 8" riser pipe or check class, schedule or pipe. Schedule 80 pipe will not work for riser pipe.

Backwater Valve Installation

STEP 1 Prepare Connecting Pipe - Cut pipe ends square; deburr and bevel as shown below. Proper cutting tools are recommended.

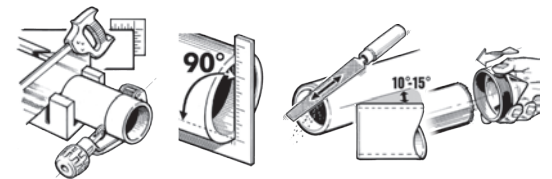

STEP 2 Install the valve body in the sewer lateral with the "FLOW" arrow on the body pointing downstream. Use the recommended Spears® solvent cement and primer. Rotate the valve body until the 8" opening is facing directly upward. A level may be used across the top of the valve body to verify horizontal positioning.

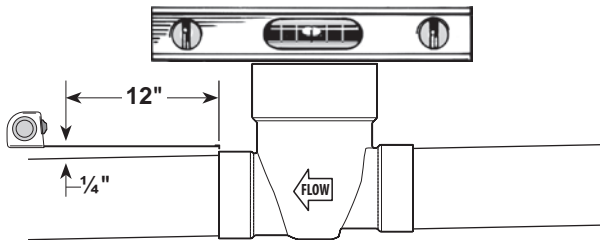
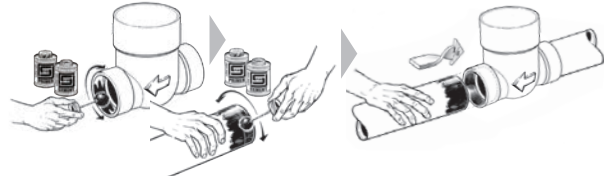

CAUTION: Valve must be installed horizontally with proper direction of flow. Do not install upside down.

STEP 3 Cut the 8" riser pipe to the required length. Cement and insert while keeping the inside of the body clean of debris.

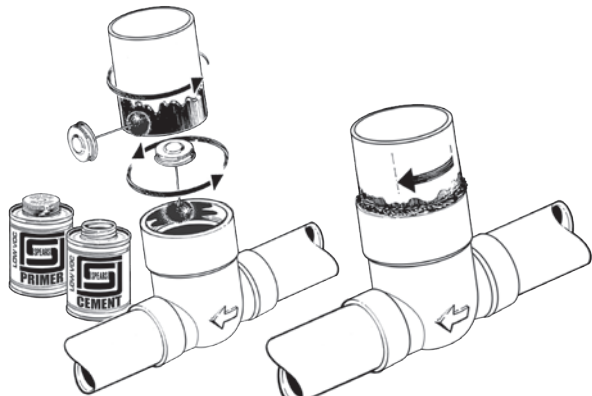

Refer to Solvent Cement Installation Guidelines for accepted joining procedures and cure times.

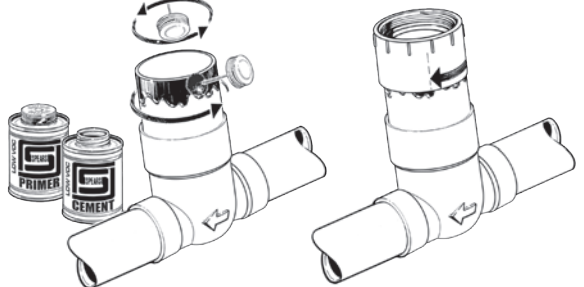

STEP 4 Cut the 1" or 1-1/4" internal extension pipe to a length so that it has approximately 1/4" clearance to access plug when access is tightened to its working position.

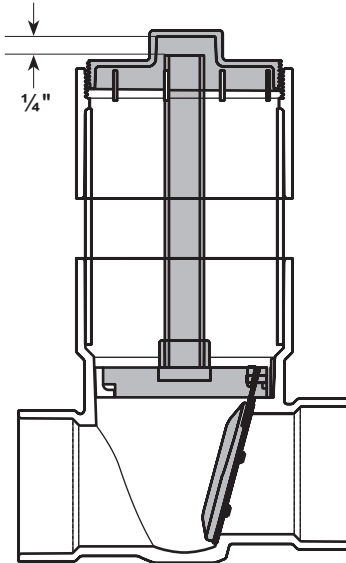

STEP 5 Cement flapper assembly to one end of the internal extension pipe.

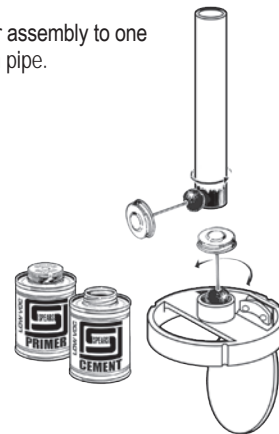

STEP 6 Insert flapper assembly then install lid and tighten.

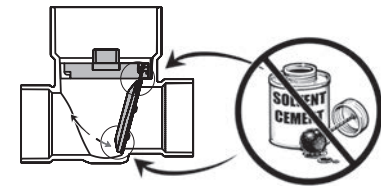
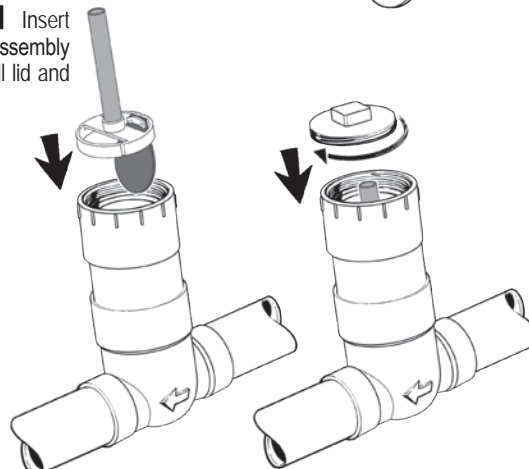

CAUTION – DO NOT allow solvent cement to come in contact with the internal body or flap assembly. This could prevent proper operation and sealing.

Standard Valve Dimensions

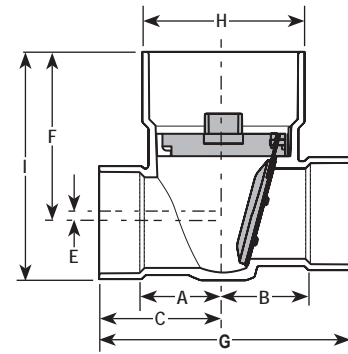

VALVE DIMENSIONS

Size	A	B	C	E	F	G	H	I
6"	4-15/16	4-15/16	8	1/2	9-15/16	15-15/16	9-3/8	13-9/16

WARNING: ALL AIR MUST BE BLED FROM THE SYSTEM DURING INITIAL FLUID FILL. PRESSURE TESTING OF THE SYSTEM SHOULD NOT BE MADE UNTIL ALL SOLVENT CEMENT JOINTS HAVE PROPERLY CURED. INITIAL PRESSURE TESTING SHOULD BE MADE AT APPROXIMATELY 10% OF THE SYSTEM HYDROSTATIC PRESSURE RATING TO IDENTIFY POTENTIAL PROBLEMS PRIOR TO TESTING AT HIGHER PRESSURES.

WARNING: SYSTEMS SHOULD NOT BE OPERATED OR FLUSHED OUT AT FLOW VELOCITIES GREATER THAN 5 FEET PER SECOND.

